

# 6.75 Gross Torque 190 CC

Bore 2.69 in. (68.3 mm)  
Stroke 2.04 in. (51.8 mm)  
Oil Capacity 18-20 fl. oz. (0.53 - 0.59 L)



## Features:

- Large rewind starter reduces pulling effort for easy starts
- Maintenance-free Magnetron® electronic ignition for quick, dependable starts
- Mechanical compression release for smooth, quick starting
- Maxi-Clean™ automotive-type pleated paper air filter provides superior protection for long engine life
- Mechanical torque control for additional power
- Composite camshaft and aluminized Lo-Tone™ muffler for low noise operation
- One-Start float carburetor assures consistent one-pull starts
- Buyer protection package provides two-year consumer engine warranty

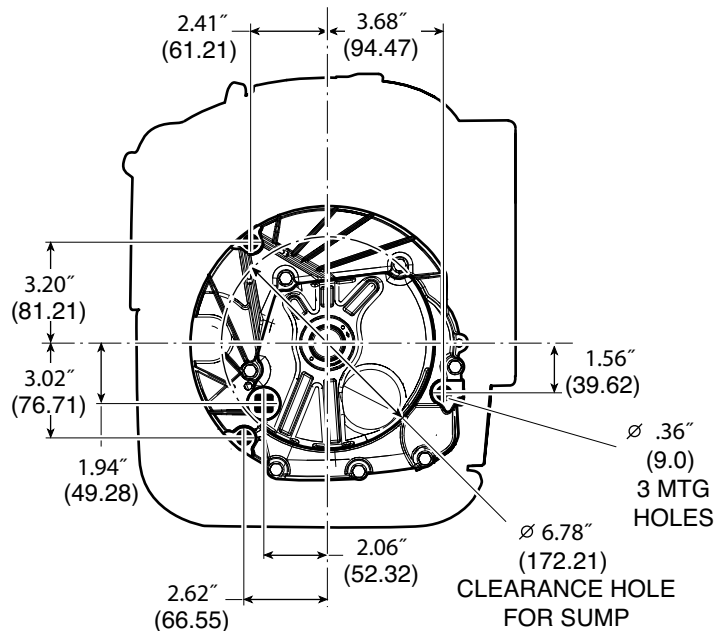
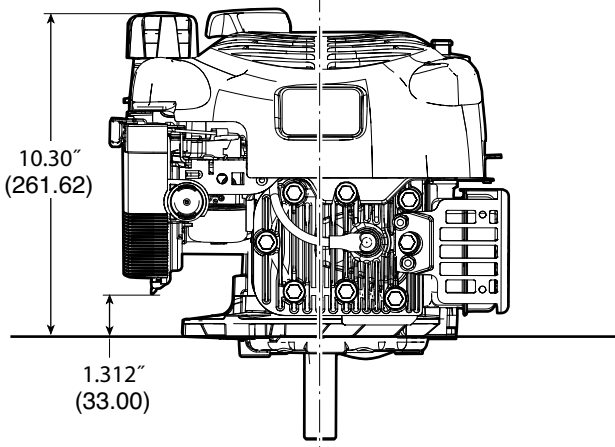
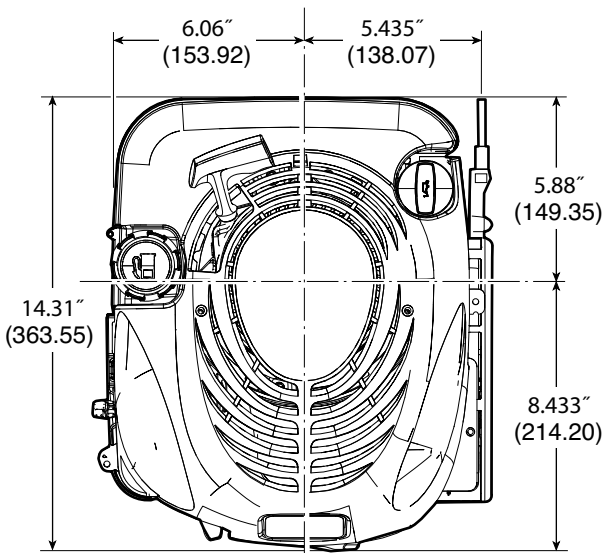

## 6.75 Gross Torque 190 CC

Model Type	Shipping Weight	Crankshaft	Crankshaft (P.T.O.) Extension	Dimension	Starter Position	Heavy Flywheel	Ext. Starter Rope	Governor	Controls	Fuel Tank (Quarts)	Primer Carburetor	5 Position Choke	Ready Start	High Debris Air Inlet	Top Governor Speed	Notes
<b>126L02</b>																
1002	33	694850	Tapped 3/8-24, 2 WK & Keyway, 7/8" dia	3-5/32(b)	6	X		M	MF	1.6		X			3100	
1003	33	694850	Tapped 3/8-24, 2 WK & Keyway, 7/8" dia.	3-5/32(b)	6	X	X	M	MF	1.6	X				3100	
1004	32	691451	Tapped 3/8-24, 2 WK & Keyway, 7/8" dia.	3-5/32(b)	6	X		M	MF	1.6		X			3100	
1005	32	797372	Tapped 3/8-24, WK & Keyway, 7/8" dia.	1-13/16(b)	6	X	X	M	MF	1.6		X			3700	
1009		691452	Tapped 3/8-24, WK & Keyway, 7/8" dia.	2-7/16(b)	6		X	M	R/MF	1.6			X	X	3100	▼
1010	33	691451	Tapped 3/8-24, 2 WK & Keyway, 7/8" dia.	3-5/32(b)	6	X	X	M	R	1.6	X			X	3600	
1011	29	691451	Tapped 3/8-24, 2 WK & Keyway, 7/8" dia.	3-5/32(b)	6		X	M	R/MF	1.6	X			X	3600	▼
1014		797372	Tapped 3/8-24, 2 WK & Keyway, 7/8" dia.	1-13/16(b)	6	X	X	M	R/MF	1.6			X		3700	
1015	29	691451	Tapped 3/8-24, 2 WK & Keyway, 7/8" dia.	3-5/32(b)	6		X	M	R/MF	1.6	X				3100	▼
1016	28	691452	Tapped 3/8-24, WK & Keyway, 7/8" dia.	2-7/16(b)	6		X	M	R/MF	1.6	X				3100	▼
1018	29	691455	Tapped 3/8-24, WK & Keyway, 7/8" dia.	1-13/16(b)	6		X	M	R/MF	1.6	X				3100	▼
1025	29	691450	Tapped 3/8-24, 2 WK & Keyway, 25mm dia.	3-5/32(b)	6		X	M	R/MF	1.6	X				3100	▼
1026	28	691454	Tapped 3/8-24, 2 WK & Keyway, 25mm dia.	2-7/16(b)	6		X	M	R/MF	1.6	X				3100	▼
1030	30	791061	Tapped 7/16-20, Stepped, WK, 7/8" dia.	1-5/32(b)	6	X	X	M	FC	1.6			X		3100	*
1031	29	696009	Tapped 7/16-20, Keyway, 25mm dia.	3-5/32(b)	6		X	M	R/MF	1.6			X		3100	▼
1615	29	691451	Tapped 3/8-24, 2 WK & Keyway, 7/8" dia.	3-5/32(b)	5		X	M	MF	1.6			X		3100	▼
1625	30	691450	Tapped 3/8-24, 2 WK & Keyway, 25mm dia.	3-5/32(b)	5		X	M	MF	1.6			X		3100	▼
1701	28	694079	Tapped 7/16-20, 25mm Taper	3-5/16(b)	6			M	MF	1.6	X				3100	▼
<b>126L07</b>																
1050	33	691451	Tapped 3/8-24, 2 WK & Keyway, 7/8" dia.	3-5/32(b)	6		X	M	R/MF	1.6	X			X	3600	
1060	38	691451	Tapped 3/8-24, 2 WK & Keyway, 7/8" dia.	3-5/32(b)	6		X	M	R/MF	1.6	X				3100	▼■
1062	38	691450	Tapped 3/8-24, 2 WK & Keyway, 25mm dia.	3-5/32(b)	6		X	M	R/MF	1.6	X				3100	▼■
1660	33	691451	Tapped 3/8-24, 2 WK & Keyway, 7/8" dia.	3-5/32(b)	5		X	M	MF	1.6			X		3100	▼■
1662	33	691450	Tapped 3/8-24, 2 WK & Keyway, 25mm dia.	3-5/32(b)	5		X	M	MF	1.6			X		3100	▼■
<b>126L12</b>																
1006	33	691455	Tapped 3/8-24, WK & Keyway, 7/8" dia.	1-13/16(b)	6	X		M	R/MF	1.6		X			3600	
1007	27	691452	Tapped 3/8-24, WK & Keyway, 7/8" dia.	2-7/16(b)	12	X		M	MF	1.6		X			3600	

▼ The features on this engine are designed to meet Section 1205.5 of the Consumer Product Safety Commission Safety Standards.

■ Engine equipped with 12 Volt Gear Drive Starter and .5 Amp DC Alternator. \* BBC Crank Shaft