

Vanguard™ 9.0 Gross HP

297 CC

Bore 3.15 in. (80 mm)

Stroke 2.32 in. (59 mm)

Oil Capacity 32 fl. oz. (.95 L)



Features:

- Dura-Bore™ cast iron cylinder sleeve for extended life
- Maintenance-free Magnetron® electronic ignition for quick, dependable starts
- Dual-Clean™ air cleaner pleated paper filter with a foam pre-cleaner ensures maximum protection for extended engine life
- Oil Gard low oil engine shutdown device
- Overhead valve design (OHV) for cooler operation and longer valve life
- Buyer protection package provides three-year commercial limited warranty

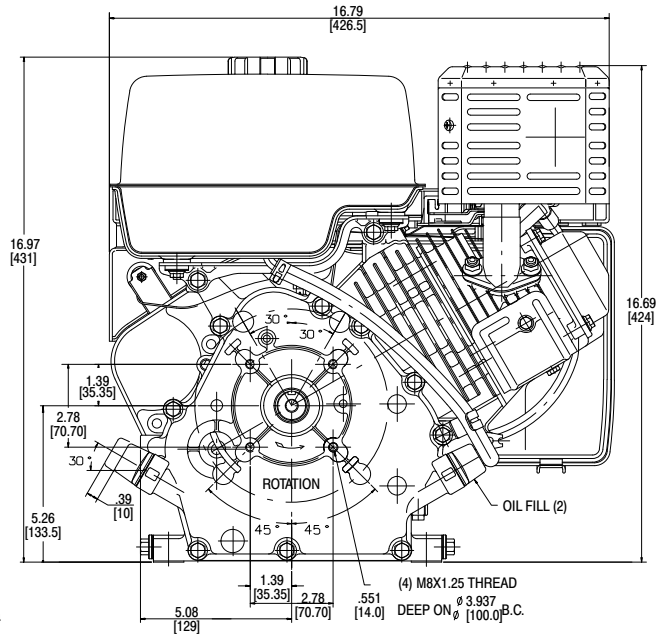
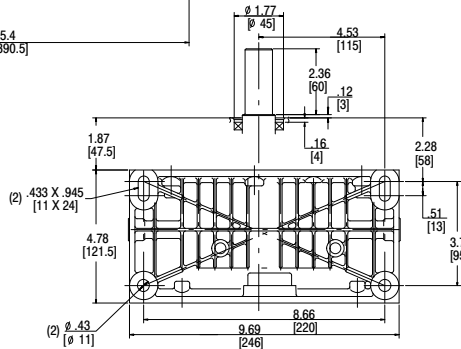
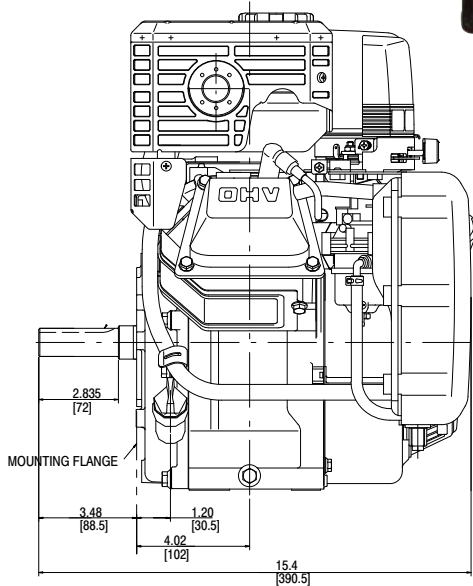

Model Type	Shipping Weight	Crankshaft	Crankshaft (P.T.O.) Extension	Dimension	Starter Position Bolt-On/Changeable	Governor	Controls	Flange Mtg.	Manual Choke	Rocker Stop Switch	Oil Gard	Fuel Tank (Quarts)	Top Governor Speed	Notes
185432														
0235	63	711565	1" dia., Keyway, tapped 7/16-20	3-21/32(c)	10:30	M	AG/R/MF	X	X	X	X	8.3	3600	•
0246	62	711565	1" dia., Keyway, tapped 7/16-20	3-21/32(c)	10:30	M	AG/R/MF	X	X	X	X	8.3	3600	• ■
0247	63	715100	Threaded 1-14, 1" tapped length	3-21/32(c)	10:30	M	AG/R/MF	X	X	X	X	8.3	3600	•
0270	68	715101	Tapered, tapped 5/16-24	4-11/32(c)	10:30	M	AG	X	X	X	X	8.3	3750	•
185437														
0284	71	711565	1" dia., Keyway, tapped 7/16-20	3-21/32(c)	10:30	M	AG/R/MF	X	X	X	X	8.3	3600	• ◆

• Ball bearing PTO and magneto side ■ Small high mount air cleaner
◆ Engine equipped with 12 Volt Gear Drive Starter and 10 Amp DC Alternator with Starter Panel Assembly.