

Vanguard™ 16.0 Gross HP 479 CC

Bore 2.68 in. (68 mm)
Stroke 2.60 in. (66 mm)
Oil Capacity: 48 fl. oz. (1.42 L)



Features:

- Dura-Bore™ cast iron cylinder sleeve for extended life
- Float carburetor for consistent easy starting
- Maintenance-free Magnetron® electronic ignition for quick, dependable starts
- Dual-Clean™ air cleaner pleated paper filter with a foam pre-cleaner ensures maximum protection for extended engine life
- Full pressure lubrication with spin-on oil filter assures controlled lubrication for extended component life
- Overhead valve design (OHV) for cooler operation and longer valve life
- Buyer protection package provides three-year commercial limited warranty

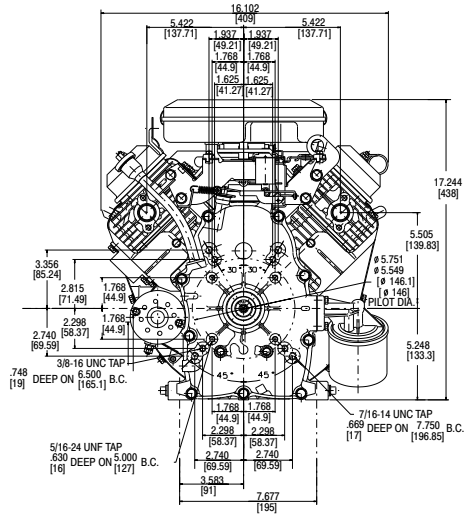
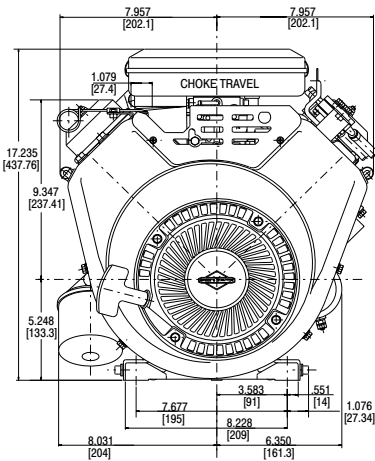
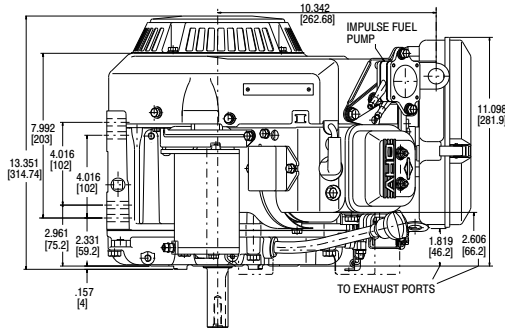

Model Type	Shipping Weight	Crankshaft	Crankshaft (P.T.O.) Extension	Dimension	Starter Position Bolt-On/Changeable	Oil Filler & Drain	Governor	Controls	Exhaust System	Fuel Tank (Quarts)	Pulse Fuel Pump	Flange Mtg.	Oil Pump w/Filter	Manual & Remote Choke	Top Governor Speed	Notes
305442																
0027	95	692161	1" dia., Keyway, tapped 3/8-24	2-29/32(c)	9	*	M	AG/R/MF	•	9		X	X	X	3600	
305447																
0005	89	692163	Tapered, drill & tapped 5/16-24	3-51/64(c)	9	*	E	FC	•	■	X	X	X		3600	◆
0023	96	692161	1" dia., Keyway, tapped 3/8-24	2-29/32(c)	9	*	M	AG/R/MF	•	9		X	X	X	3600	◆
0068	103	692161	1" dia., Keyway, tapped 3/8-24	2-29/32(c)	9	*	M	AG/R/MF	•	9		X	X	X	3600	◆
0075	87	692161	1" dia., Keyway, tapped 3/8-24	2-29/32(c)	9	*	M	AG/R/MF	•	■	X	X	X	X	3600	◆
0077	88	692162	Threaded 1-14, 1" thread length	3-21/32(c)	9	*	M	AG/R/MF	•	■	X	X	X	X	3600	◆
0078	87	692163	Tapered, drill & tapped 5/16-24	3-51/64(c)	9	*	M	AG	•	■	X	X	X		3750	◆
0079	86	692161	1" dia., Keyway, tapped 3/8-24	2-29/32(c)		*	M	AG/R/MF	•	■	X	X	X	X	3600	◆
0087	90	808740	1/8" dia, Keyway, tapped 7/16-20	4(c)	9	*	M	AG/R/MF	•	■	X	X	X	X	3600	◆

• Exhaust manifold and muffler omitted. See Briggs & Stratton Master Parts Catalog MS-4185 for Exhaust Manifold and Muffler Options. * Oil fill and dipstick in cover; dual drain. ■ Fuel tank omitted. ◆ Engine equipped with 12 Volt Gear Drive Starter and 16 Amp DC Alternator with Starter Panel Assembly.