

Professional Series™

27.0 Gross HP

724 CC

Bore 3.12 in. (79.2 mm)
 Stroke 2.89 in. (73.4 mm)
 Oil Capacity 64 fl. oz. (1.9 L)

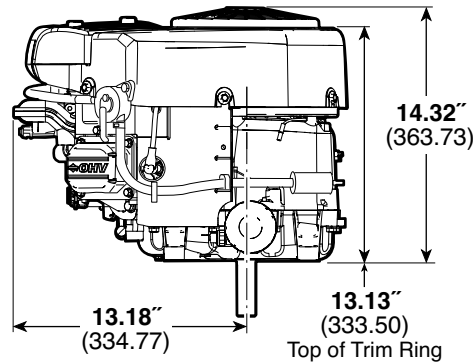
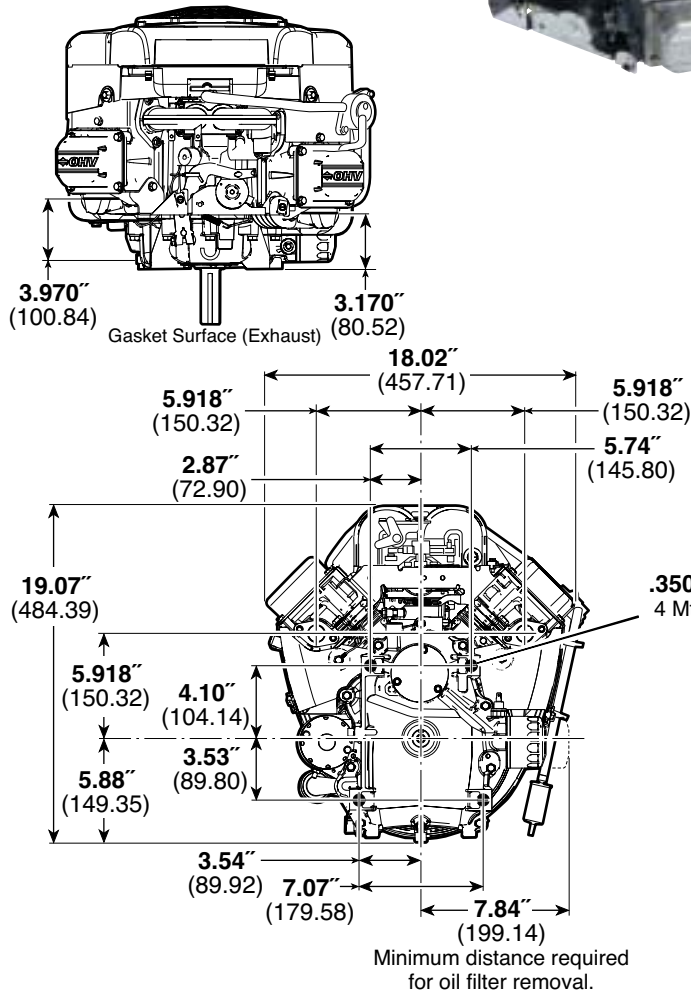

Features:

- Dura-Bore™ cast iron cylinder sleeve for extended life
- Dependable float feed type carburetor with integral fuel pump for remote mount fuel tank
- Maintenance-free Magnetron® electronic ignition for quick, dependable starts
- Mechanical compression release for smooth, quick starting
- Advanced Debris Management System with a dual seal, cartridge-style air filter provides maximum protection and extends engine life
- Full pressure lubrication with spin-on oil filter assures controlled lubrication for extended component life
- Overhead valve design (OHV) for cooler operation and longer valve life
- Platinum spark plugs for extended life
- Premium oil filter
- Buyer protection package provides two-year consumer engine warranty

Model Type	Shipping Weight	Crankshaft	Crankshaft (P.T.O.) Extension	Dimension	Governor	Controls	Exhaust System	Fuel Tank (Quarts)	Ground Wire Terminal	Ext. Oil Fill & Dipstick	Oil Pump w/Filter	Remote Choke	Choke-A-Matic®	Electronic Fuel Management	Top Governor Speed	Notes
44Q777																
0046		796256	Tapped 7/16-20, Keyway, 1-1/8" dia.	4-5/16(b)	M	R	•	■	X	X	X			X	3300	†
0047		796237	Tapped 7/16-20, Keyway, 1 dia.	3-5/32(b)	M	R	•	■	X	X	X			X	3300	†
0135	95	796257	Tapped 7/16-20, Keyway, 1" dia.	4-5/16(b)	M	R	•	■	X	X	X		X		3300	†
0136	96	796256	Tapped 7/16-20, Keyway, 1-1/8" dia.	4-5/16(b)	M	R	•	■	X	X	X		X		3300	†
0137	94	796237	Tapped 7/16-20, Keyway, 1" dia.	3-5/32(b)	M	R	•	■	X	X	X		X		3300	†

• Exhaust manifold and muffler omitted. ■ Fuel tank omitted. † Engine equipped with 12 Volt Gear Drive Starter and 16 Amp DC Alternator.