

HONDA
ENGINES

GC 135

Horizontal shaft gasoline (petrol) engine

- Moteur à essence à arbre de sortie horizontal
- Benzinmotor mit horizontaler Kurbelwelle
- Motore a benzina ad albero orizzontale



2.9 kW (4 HP) / 3 600 min⁻¹

Dimensions Unit: mm (in.)

STANDARD TYPE

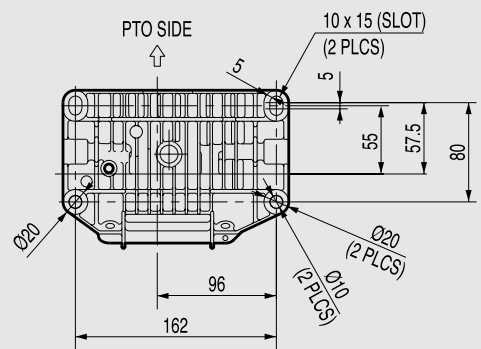
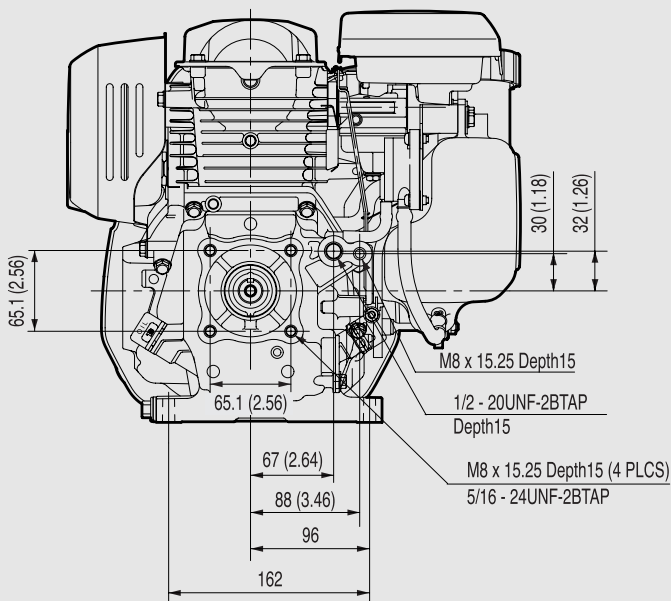
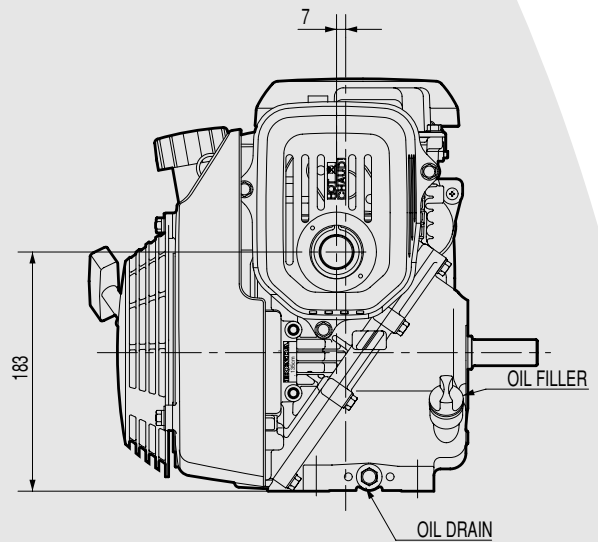
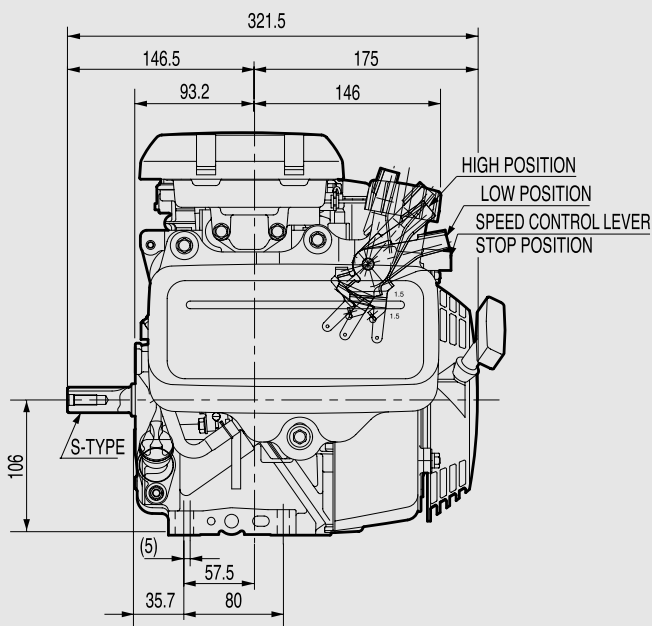
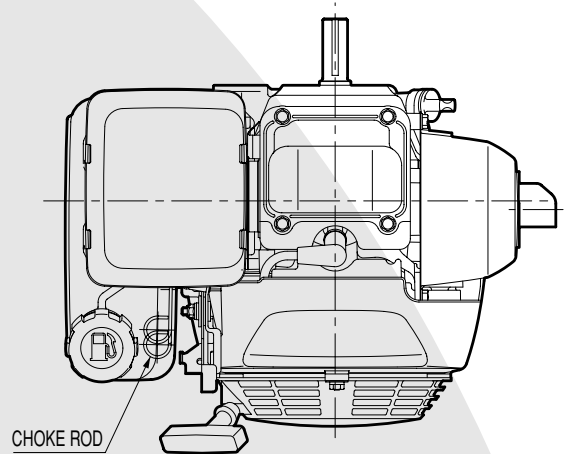
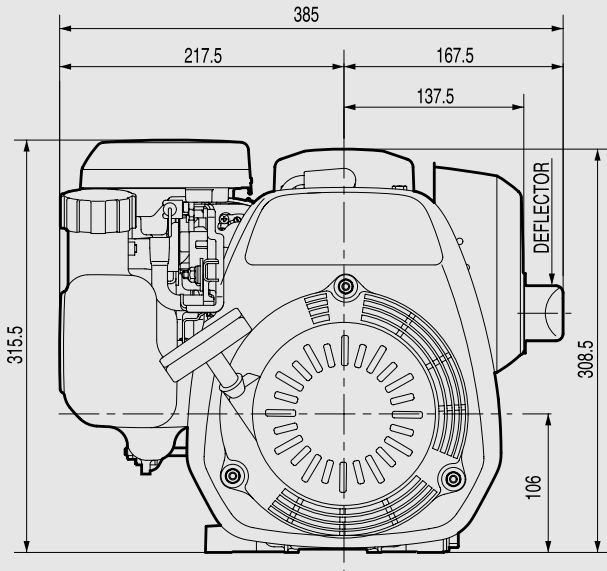

POWERED by
Honda Engines



Specifications

| Model | GC 135 |
|------------------------|-----------------------------------------------------------------------------|
| Engine type | Air cooled 4 stroke OHC petrol engine, horizontal shaft, aluminium cylinder |
| Bore x stroke | 64 x 42 mm |
| Displacement | 135 cm ³ |
| Compression ratio | 8.5 : 1 |
| Max. power output | 2.9 kW (4.0 HP) / 3 600 rpm |
| Maximum torque | 8.6 Nm / 0.88 kgm / 2 500 rpm |
| Ignition system | Transistorised |
| Starting system | Recoil |
| Aircleaner type | Paper |
| Fuel tank capacity | 1.7 l |
| Specific fuel cons. | 313 g/kW.hr - 230 g/HP.hr |
| Engine oil capacity | 0.6 l |
| Dimensions (L x W x H) | 322 x 365 x 315 mm |
| Dry weight | 11.3 kg |

Spécifications techniques

| Modèle | GC 135 |
|--------------------------|---------------------------------------------------------------------------------------------------------------------|
| Type du moteur | Moteur à essence monocylindre 4 temps OHC, refroidissement à air, arbre de sortie horizontal, cylindre en aluminium |
| Alésage x course | 64 x 42 mm |
| Cylindrée | 135 cm ³ |
| Taux de compression | 8.5 : 1 |
| Puissance maxi | 2.9 kW (4.0 ch) / 3 600 tr/mn |
| Couple maximal | 8.6 Nm / 0.88 kgm / 2 500 tr/mn |
| Système d'allumage | Transistorisé |
| Système de démarrage | Lanceur à retour automatique |
| Type du filtre à air | Papier |
| Cap. du réservoir d'ess. | 1.7 l |
| Cons. d'essence spéc. | 313 g/kW.h - 230 g/ch.h |
| Capacité d'huile moteur | 0.6 l |
| Dimensions (L x l x H) | 322 x 365 x 315 mm |
| Poids à sec | 11.3 kg |

All specifications are subject to change without notice. Les caractéristiques techniques peuvent être modifiées à tout moment et sans préavis.

Spezifikationen

| Modell | GC 135 |
|---------------------------|---------------------------------------------------------------------------------------------|
| Motortyp | Luftgekühlter 1-Zylinder 4-Takt OHC Benzinmotor, horizontale Kurbelwelle, Aluminiumzylinder |
| Bohrung x Hub | 64 x 42 mm |
| Hubraum | 135 cm ³ |
| Verdichtung | 8.5 : 1 |
| Höchstleistung | 2.9 kW (4.0 PS) / 3 600 min ⁻¹ |
| Max. Drehmoment | 8.6 Nm / 0.88 kgm / 2 500 min ⁻¹ |
| Zündsystem | Elektronische Zündung |
| Starter | Reversierstarter |
| Luftfilter | Papier |
| Tankinhalt | 1.7 Liter |
| Spez. Kraftstoffverbrauch | 313 g/kWh - 230 g/PSH |
| Motorölkapazität | 0.6 Liter |
| Maße (L x B x H) | 322 x 365 x 315 mm |
| Trockengewicht | 11.3 kg |

Dati tecnici

| Tipo | GC 135 |
|--------------------------|-----------------------------------------------------------------------------------------------------------------------------|
| Tipo di motore | Motore monocilindrico OHC ad albero orizzontale, ciclo otto, 4 tempi, raffreddamento ad aria forzata, cilindro in alluminio |
| Alesaggio x corsa | 64 x 42 mm |
| Cilindrata | 135 cm ³ |
| Rapporto di compressione | 8.5 : 1 |
| Potenza massima | 2.9 kW (4.0 CV) / 3 600 giri/min |
| Coppia massima | 8.6 Nm / 0.88 kgm / 2 500 giri/min |
| Accensione | A transistor senza contatti |
| Avviamento | A strappo con autoavvolgente |
| Sistema filtro aria | A secco |
| Capacità serbatoio | 1.7 l |
| Consumo combustibile | 313 g/kWh - 230 g/CVh |
| Capacità coppa olio | 0.6 l |
| Dimensioni (Lu x La x A) | 322 x 365 x 315 mm |
| Peso a secco | 11.3 kg |

Le specifiche sono soggette a cambiamento senza preavviso. Die Spezifikationen können ohne Vorankündigung geändert werden.

Ref. EEC - TS 2002/08 - GC 135

hella@iohta.com

Germany • Honda Engines / Selling agent
Honda Logistik Center Deutschland GmbH
Sprendlinger Landstraße 166
D-63069 Offenbach/Main
TEL: + 49 (0)6 98 30 95 17
FAX: + 49 (0)6 98 30 91 28

United Kingdom • Honda Engines / Selling agent
Honda Logistics Centre (UK) Ltd.
Unit 3210, Wellington Parkway,
Magna Park Lutterworth,
Leicestershire LE 17 4JQ United Kingdom
TEL: + 44 (0)1 45 55 59 429
FAX: + 44 (0)1 45 55 59 428

HONDA
ENGINES

Honda Europe NV
EUROPEAN ENGINE CENTER
Langerbruggestraat 104 • B-9000 Gent
TEL: + 32 (0)9 250 12 11 • FAX: + 32 (0)9 250 14 24

Italy • Honda Engines / Selling agent
Honda Logistic Centre Italy S.P.A.
Via Strà, 153
I-37030 Colognola ai Colli (VR)
TEL: + 39 04 56 17 33 41
FAX: + 39 04 56 15 12 70

France • Honda Engines / Product information center
Parc d'Activités de Pariest
Allée du 1er Mai
Croissy Beaubourg
F-77313 Marne-La-Vallée Cedex 13
TEL: + 33 (0)1 60 37 31 18
FAX: + 33 (0)1 60 37 33 66